

# Performance enhancement of grid connected inverter with input of two PV array under different environmental conditions using ANFIS control

Pawan Kumar Vishwakarma<sup>#1</sup>, Priyanka Maheshwari<sup>\*2</sup>, Dr Sanjay Jain<sup>#3</sup>

*M.Tech (Electrical Power System) Scholar, RKDF University Bhopal, India<sup>#1</sup>*

*Assistant Professor, Department of Electrical Engineering, RKDF University Bhopal, India<sup>#2</sup>*

*Head of Department, Department of Electrical Engineering, RKDF University Bhopal, India<sup>#3</sup>*

[pawan.vishwakarma@gmail.com](mailto:pawan.vishwakarma@gmail.com)

[priyankabits4@gmail.com](mailto:priyankabits4@gmail.com)

[jain.san12@gmail.com](mailto:jain.san12@gmail.com)

**Abstract-** Solar PV cells-based grid connected inverters are particularly popular nowadays. At times the PV may have a different environmental condition like different irradiance or temperature. The current innovations in grid connected PV inverter are not having a lot of stable yields or stability for this situation. In this paper, an enhanced control framework system is intended for two PV which are mismatched under different factors which constitutes a highly efficient grid connected solar inverter, which will have THD under 1% for both voltage and current. The regulator utilizes a control system which consists of ANFIS based control system which is in hybrid contribution with incremental conductance technique of MPPT. The results are simulated and verified on MATLAB Simulink.

**Keywords** - PV, solar, ANFIS, Inverter, Grid Connected

## I. INTRODUCTION

The working environment and temperatures greatly affect the solar panels. It is important to get an output with high stability while working with many arrays together. [1] The aftereffects basically deal with loss or power output and stability and high distortions in the case of solar based grid connected inverters. [2] when there are many arrays, and the output is under high distortions may affect the load connected in certain way of lifetime. There is high demand in solar based inverters currently which increases the enthusiasm amongst the researchers for better distortion less waveforms. [3] this also gave interest in buck and boost-based inverters instead of traditionally the transformer based which are bulky and costly and cannot be controlled through the transformers. In this manner, the power yield from a structure related transformer less PV system, for instance, single stage inverter-based systems got from more interests and inverter-based systems get affected in this case. [4]

The enthusiasm of limitless resources has been growing rapidly in light of the environmental concerns and need of imperativeness which makes sources like solar and wind very useful and promising in nature. [5] Solar or photovoltaic essentialness is basically right now one of the very most notable and supportable power source resources. Inverter is major part in network related PV structures and inverter is highly used in any scenario for power generation and is very basic requirement. [6] This research bases on the checks of inverter for structure related PV system, a couple of inverter designs for interfacing PV based arrays to the three phase or single-stage framework with their positive conditions and hindrances. At the most required points is the distortion less inverter which utilizing one or more solar PV arrays and is not affected by any environmental constraints. [7] The PV power system is applied to authentically change over solar imperativeness into electrical essentialness utilizing solar cells. The guideline (Size 10 & Normal) This document is a template. An electronic copy can be downloaded from the conference website. For questions on paper guidelines, please contact the conference publications committee as indicated on the conference website. Information about final paper submission is available from the conference website.

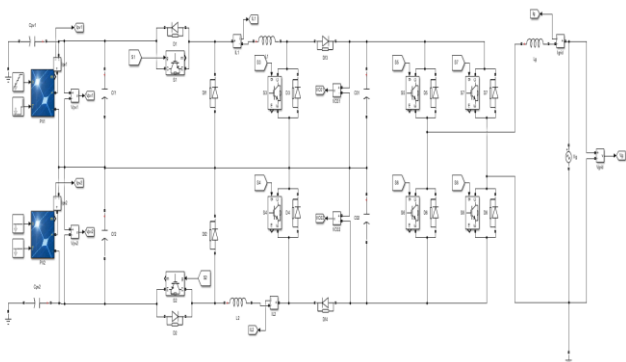
parts of the system are solar cells, battery, regulator, booster and inverter. Characterized by high constancy, long help life, no tainting, and making power self-governing, it gets the benevolence of public endeavours, and has enormous potential for future improvement. [8] Thusly, the improvement and utilization of solar imperativeness is an incredibly brilliant system for understanding the difficulty of power gracefully in far off district. The monitoring structures of PV based system are generally controlled by different kind of control systems which in turn give many design opportunities and new calculative based response for the inverter. There are many traditional controllers for tacking the maximum power point just like in general Perturb and Observe, PI proportional integral control and ANFIS is also amongst the machine

learning and artificial intelligence techniques can also be implemented to monitor the grid connected PV inverter. [10] By introducing a buck and boost the above control are able to reduce error between the PV arrays and hence improving the output yield but with higher distortions. [11] The basic reliability amongst the control system that it can be manipulated in such a manner that a high repeat activity without extending the trading setback is ensured which improves the error efficiency in the grid connected PV inverter. High repeat activity similarly prompts the lessening in the size of the uninvolved parts which involves the benefit of using buck and boost-based inverters. [12]

A single stage structure related transformer less photovoltaic solar grid connected inverter for application is presented in this paper. Application of buck and boost configurations enable the grid connected inverter [13]. The need is to improve the distortions present if any using different control strategies as PV inverter promises more scope under the future for free source power in grid with very low maintenance cost [14]. As such, interleaved distinctive stage's structure is proposed to have minimal corresponding inductance, in the meantime the wave distortions can be improved, and the transformer use can be diminished as well. More phases under the influence of PV can also be introduced in a similar way. Using a solar inverter easier conversion with higher efficiency can be achieved in grids which is very useful conversion of DC voltage to AC voltage as required. [15] In this paper, an attempt is made to improve the performance of mismatched environmental condition based two PV inverter using a specialized controller technique which is known as ANFIS with Modified Incremental Conductance.

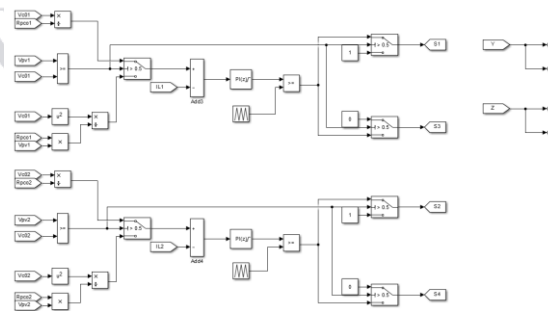
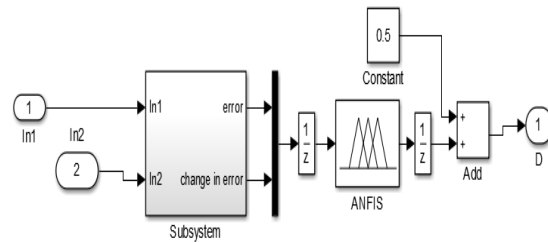
**II. IMPLEMENTATION**

Presently, the execution appeared in past segment is changed for the proposition of the new work from the base work [1]. In this work, rather than only IC MPPT conductance technique, here, ANFIS based control regulator is applied for higher accuracy and lower distortions. In figure 1, the circuit outline is taken as existing to make examination for results, to improve this circuit, ANFIS is applied.



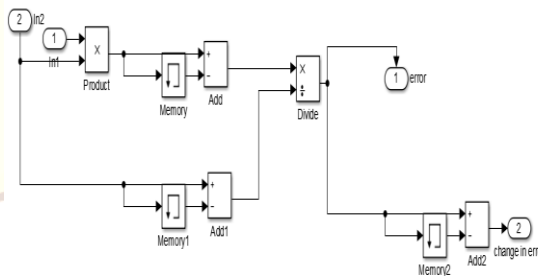
**Figure 1: Final Model for Two PV array Inverter**

In figure 2, the ANFIS regulator is appeared, in the subsystem the power is determined which brings about change in power that is mistake and change in noise of power as two sources of info which are multiplexed and taken into the input of the ANFIS regulator in the attempt to improve the error which was generated using the PV arrays in mismatched environmental conditions. This yield included with a factor which improves the distortion proportion for both current and voltage outputs.

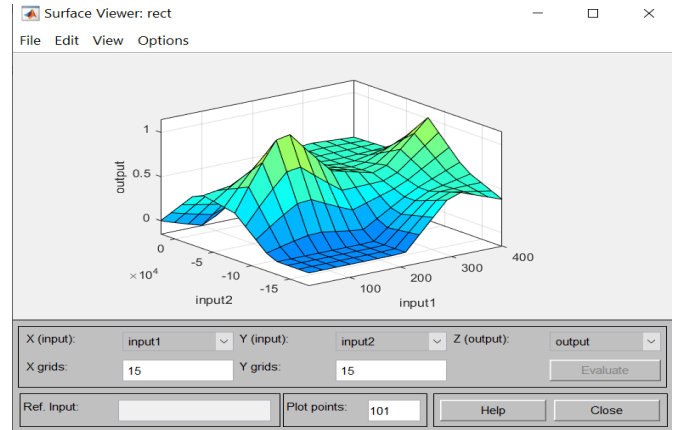
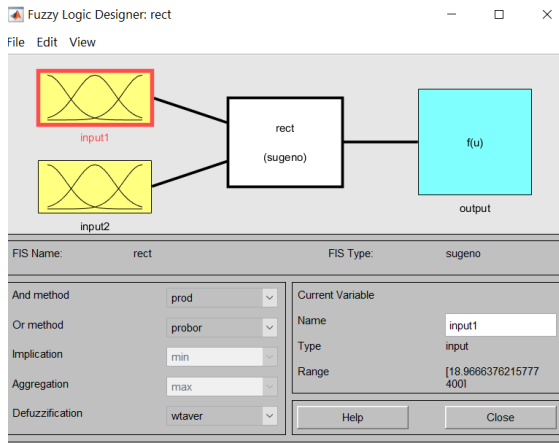


**Figure 2: ANFIS Controller for Two PV inverter**

In figure 3, the subsystem is characterized for giving error and change in distortion yield from the current and voltage from PV exhibits. Here, two ANFIS regulators are applied for each PV cluster on the grounds that the PV exhibits are mismatched and may make various yields and mismatches.



**Figure 3: Subsystem for Power Error and Change in Error**



**Figure 5: The Surface View and model structure of Rules range**

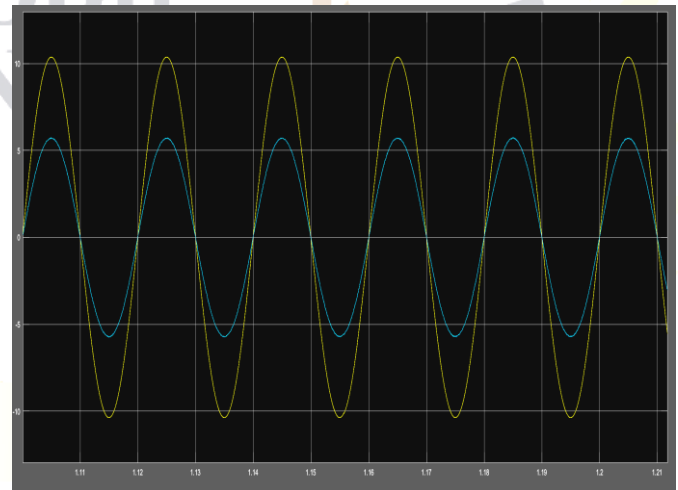
In figure 5, the rules defined in two PV arrays ANFIS controller are shown in a surface view graph.



**III.RESULTS:**

**Figure 4: ANFIS Toolbox and rule view for Power Error and Change in Error and Output**

In figure 4, the ANFIS regulator tool is introduced, which shows the standards utilized are Sugeno for the ANFIS regulators.



**Figure 6: Output Current and Voltage of Inverter**

In figure 6, the zoomed output of current and voltage shows sine wave, which is perfectly fine.

From the results shown in previous section, the final comparison is given in table 1 shown below. The results are improved for proposed work.

**Table 1: Comparison results for Two Inverters**

	Existing	Proposed
<b>THD Voltage</b>	0.09%	0.05%
<b>THD Current</b>	2.12%	0.43%

Also, the results are shown graphical in comparison, which is presented in figure 7 and figure 8 below.



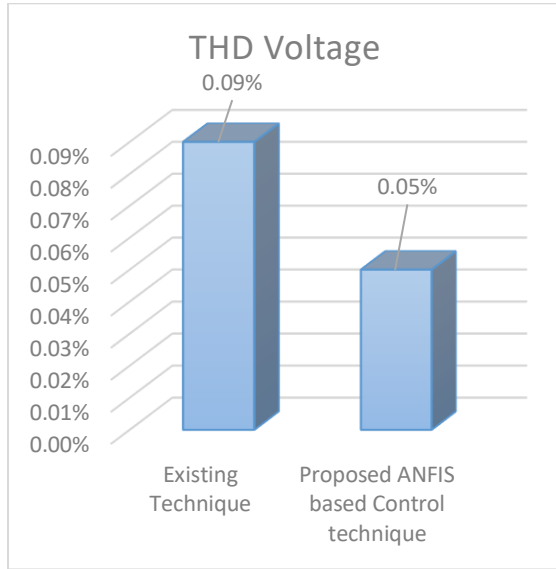


Figure 7: THD comparison for Voltage

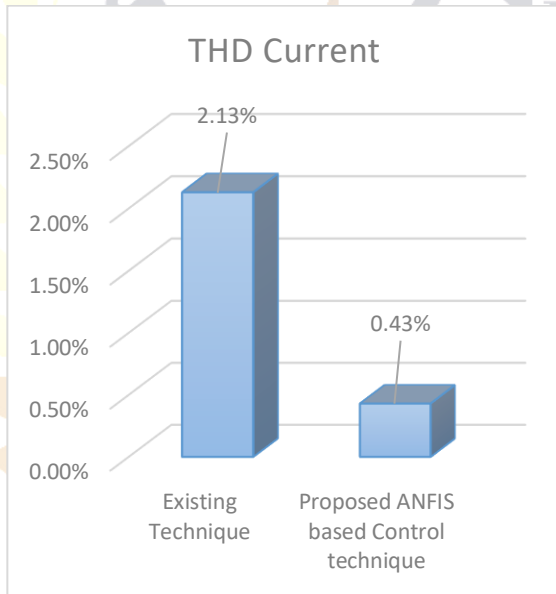


Figure 8: THD comparison for current

**IV. CONCLUSION:**

In this paper, the execution of two PV based arrays in mismatched natural environmental conditions are actualized to shape an inverter with less noises and distortions. The work is effectively executed with results in MATLAB Simulink. The distortions are decreased beneath 0.5% and the yields give productivity over 99.5%. the yield current and voltage waveform show accurate yield additionally for PV yields low variances are watched. The ANFIS regulator ends up being best as far as accuracy as it takes likewise the questionable states of the error detections and change in mismatch of the power in MPPT.

**REFERENCES**

[1] Subhendu Dutta, and Kishore Chatterjee, "A Buck & Boost based Grid Connected PV Inverter Maximizing Power Yield from Two PV Arrays in Mismatched Environmental Conditions" IEEE TRANSACTIONS ON INDUSTRIAL ELECTRONICS DOI 10.1109/TIE.2017.2774768, IEEE

[2] Muhammedali Shafeeque K, Subadhra P.R, "A Novel Single Stage DC-AC Buck Boost Inverter for Solar Power Extraction" International Conference on Microelectronics, Communication and Renewable Energy (ICMiCR-2013)

[3] Sannasy Mageshwari, S. Kanagalakshmi and Hannumath Rao, "Design and Implementation of Buck-Boost Converter for Residential PV Application" International Journal on Electrical Engineering and Informatics - Volume 9, Number 4, December 2017

[4] Santosh Singh Yadav, Vaibhav Singh Chauhan, "SOLAR POWERED BUCK BOOST INVERTER BASED INVERTER TOPOLOGIES FOR DOMESTIC APPLICATIONS" 978-1-5386-9316-2/18/\$31.00 ©2018 IEEE

[5] A. Testa, S. De Caro, T. Scimone, S. Panarello, "A Buck-Boost based DC/AC Converter for Residential PV Applications" 978-1-4673-1301-8/12/\$31.00 ©2012 IEEE

[6] Prasanth Kumar Sahu, Madhav Manjrekar, Ronak Bhatt, "Maximum Power Point Tracking for Solar Panel Companion Inverters" 978-1-5090-5326-1/17/\$31 ©2017 IEEE

[7] Mohamed Ahmed Hassan El-Sayed, Steven B. Leeb, "MAXIMUM POWER POINT TRACKING OF PV ARRAYS IN KUWAIT"

[8] T.Dineshkumar, P.Thirumoorthi, S.Rajalakshmi, "Design of Boost Inverter for Solar Power Based Stand Alone Systems" International Journal of Engineering and Advanced Technology (IJEAT) ISSN: 2249 – 8958, Volume-8 Issue-6S, August 2019

[9] Komal H. Nanwani, Dagadu S. More, "A Buck-Boost Common-Mode Transformerless Inverter for Photovoltaic Applications" 978-1-5386-9316-2/18/\$31.00 ©2018 IEEE

[10] S. S. Patil, G. S. Patil, "High Efficiency Single-stage Grid-tied PV Inverter Topology for Renewable Energy System" Volume III, Issue V, May 2014 IJLTEMAS ISSN 2278 – 2540

[11] A. Zahedi, "Solar photovoltaic (PV) energy; latest developments in the building integrated and hybrid PV systems" 0960-1481/\$ - see front matter q 2005 Published by Elsevier Ltd. doi: 10.1016/j.renene.2005.08.007

[12] XU Jun, Han Kailing, "The Single-phase Inverter Design for Photovoltaic System" 2016 International Symposium on Computer, Consumer and Control

[13] Soham Deshpande, Dr. N. R. Bhasme, "A Review of Topologies of Inverter for Grid Connected PV Systems" International Conference on Innovations in Power and Advanced Computing Technologies [i-PACT2017]

[14] Shadi H. Shehadeh, Student IEEE, Hamed H. Aly, Member IEEE, and M. E. El-Hawary, "Photovoltaic Inverters Technology" Proceeding of the IEEE 28<sup>th</sup> Canadian Conference on Electrical and Computer Engineering Halifax, Canada, May 3-6, 2015

[15] O. S. Kim\*, N. A. Matchanov, M. A. Malikov, and B. R. Umarov, "A Study of Main Causes of Malfunction and Breakdown for PV Inverter and Suggestion of Some Practical Measures" ISSN 0003-701X, Applied Solar Energy, 2017, Vol. 53, No. 1, pp. 35–38. © Allerton Press, Inc., 2017.