

A Critical Review for Quality Extraction of Brain Tumor for Biomedical Image Processing

Avichal Sudhakar Asarkar¹, Akhilesh Bansiya²

¹Mtech Scholar, ²Assistant Professor, Department of CSE, RKDF University, Bhopal, M.P., India

¹asaasarkar@gmail.com, ²akhilesh2483@gmail.com

Abstract—The primary objective of this paper is to show how the de-noising calculations based upon the discrete wavelet change (DWT) can be connected effectively to improve boisterous attractive reverberation (MR) information sets i.e. two-dimensional (2-D) picture cut. Clamor expulsion or de-noising is a vital errand in picture preparing used to recoup a sign that has been ruined by commotion. Arbitrary clamor that is available in MR pictures is created specifically or in a roundabout way by electronic segments in the instrumentation. This paper exhibits a thought of 2-D picture disintegration, thresholding, Denoising, recreation, and measure of picture quality. This paper essentially shows the hypothesis of major numerical apparatuses (Discrete Wavelet Transform) that are utilized for the examination and handling of biomedical pictures. DWT assumes a noticeable part in the de-noising of MR pictures. The execution of the different de-noising calculations will be quantitatively evaluated utilizing diverse criteria to be specific the mean square mistake (MSE), top sign to-commotion proportion (PSNR) and the visual appearance. This issue will be completed in Matlab's wavelet tool compartment utilizing GUI Approach. The outcomes will likewise be talked about in understanding to the level of disintegrations, and wavelet's actualized.

Index Terms— Time-Scale Analysis, Discrete Wavelet transform, Image Denoising, Biomedical Image Processing.

I. INTRODUCTION

In this present reality, there is no impeccable path for a target appraisal of picture quality. The issue with the most target measures is that target measures require a reference unique picture to have the capacity to review the comparing tried picture, while human spectators can review picture quality freely of a relating unique picture [1]. These measurements for quality appraisal have constrained viability in foreseeing the subjective nature of genuine pictures. In any case, there is no present standard and target meaning of picture quality.

Discrete wavelet change can be utilized as a part of different picture preparing applications, for example, Image Compression, Coding and Statistical textural highlight investigation. In this paper, we look at how DWT can be utilized as a part of picture quality assessment, which has gotten to be critical for the most picture preparing applications. Nature of a picture can be assessed utilizing diverse measures. The most ideal approach to do this is by making a visual investigation, under controlled conditions, in which human spectator's evaluation which picture gives better quality. Such

examinations are tedious and excessive. A much less demanding methodology is to utilize some target measure that assesses the numeric blunder between the first picture and the tried one.

Magnetic Resonance Imaging (MRI) is an imaging strategy utilized essentially as a part of clinical conclusion and biomedical exploration to deliver high determination and high differentiation pictures of the parts of the human body, for example, the mind. The most striking focal points of MRI are its non-intrusive nature, does not bring about the hurtful ionizing radiation to the patients and the rich data that MRI can give about the delicate tissue life structures. Precise examination of MRI pictures depends not just on the aptitude of doctors or specialists additionally, progressively, on the robotized highlight extraction strategies for MRI pictures. Magnetic Resonance Imaging (MRI) has turned into a generally utilized strategy for superb restorative imaging, particularly in cerebrum imaging where MRI's delicate tissue contrast and non-obtrusiveness is a reasonable favorable position [2]. X-ray gives an unparalleled perspective inside the human body. The level of subtle element we can see is exceptional contrasted and whatever other imaging methodology. There are a few sorts of use of DWT, for example, picture Denoising Resolution Enhancements, pictures pressure and Edge Detection and so forth we will attempt to demonstrate here which wavelet is best for mind MRI Denoising at what level of disintegration. We are thinking about here level 1 and level 2 in light of the fact that taken to further levels will make issue more perplexing. In this paper, wavelet change is utilized for multi-scale signal examination. The de-noising calculations apply a picked wavelet on the wavelet disintegration and for the recreation of MRI pictures DWT diminishes the commotion effectively, safeguarding the edge subtle elements of the picture. Cases are given to demonstrate the de-noising comes about and the exploratory aftereffects of the high flag to-clamor rate could be acquired to make a correlation of the different wavelets utilized. Uses of the DWT in the restorative imaging field incorporate clamor decrease, Image Enhancement, and Segmentation, Image Reconstruction. Trials are done on 2-D information set.

Denoising of pictures adulterated by added substance white Gaussian clamor (AWGN) is an established issue in sign preparing. The mutilation of pictures by clamor is basic amid its procurement, handling, pressure, stockpiling, transmission, and proliferation. The point of

Denosing is to evacuate the clamor while keeping the sign elements however much as could be expected. Conventional calculations perform picture De-noising in the pixel space. Be that as it may, the utilization of the wavelet change in picture De-noising, pressure, and so forth has indicated exceptional accomplishment in the course of the most recent decade. Picture de-noising techniques utilizing such a methodology incorporate the Visu-Shrink, Sure-Shrink, Bayes Shrink, plentifulness scale-invariant Bayes estimator, Neigh Coeff, Spatial-connection thresholding, and experimental Bayes thresholding [3]. Standard decisions for nonlinear thresholding or shrinkage capacities are delicate and hard-thresholding, firm-shrinkage, and non-negative garrote shrinkage. Techniques utilizing such shrinkage capacities are computationally straightforward, however have certain downsides in perspective of the way that the capacities speaking to the nonlinearity are discretionarily picked. For instance, the delicate thresholding Denosing of pictures ruined by added substance white Gaussian commotion (AWGN) is a traditional issue in sign handling. The contortion of pictures by commotion is regular amid its securing, handling, pressure, stockpiling, transmission, and proliferation. The point of Denosing is to evacuate the commotion while keeping the sign components however much as could be expected. Conventional calculations perform picture De-noising in the pixel area. Notwithstanding, the utilization of the wavelet change in picture De-noising, pressure, and so forth has demonstrated momentous accomplishment in the course of the most recent decade. Picture de-noising techniques utilizing such a methodology incorporate the Visu-Shrink, Sure-Shrink, BayesShrink, sufficiency scale-invariant Bayes estimator, NeighCoeff, Spatial-relationship thresholding, and exact Bayes thresholding [3]. Standard decisions for nonlinear thresholding or shrinkage capacities are delicate and hard-thresholding, firm-shrinkage, and non-negative garrote shrinkage. Techniques utilizing such shrinkage capacities are computationally basic, yet have certain downsides in perspective of the way that the capacities speaking to the nonlinearity are self-assertively picked. For instance, the delicate thresholding system yields a one-sided gauge with a moderate fluctuation, while the hard-thresholding strategy yields a less one-sided evaluate however with a higher change. In the second approach, rather than utilizing a discretionary capacity to speak to the nonlinearity, the shrinkage capacity is planned by minimizing a Bayesian danger, ordinarily under the base mean squared mistake (MMSE) paradigm, least mean supreme blunder basis or most extreme a posteriori (MAP) standard.

II. Methodology

A. . Wavelet Transform

Wavelet change (WT) is used as of late in highlight extraction of MRIs, since the WT gives great confinement in both spatial and ghostly areas [4]. In any case, the

discrete wavelet change (DWT) is interpretation variation, specifically, the wavelet coefficients carry on erratically under interpretation of the information signal. The elements got by DWT may change surprisingly when the mind MR picture is just somewhat moved on account of the dithering of the subject. In the more awful cases, the DWT based order may even perceive two pictures from one subject as two from various subjects, when the focuses of the pictures are situated at marginally distinctive positions. The computerized change of any picture for PC handling requires digitization of pictures so we are utilizing here 2-D discrete wavelet change which breaks down a picture into a few sub-groups as indicated by a redundant procedure known as dyadic (scale and position) channel bank decay. This disintegration will produce wavelet coefficients .These coefficients will incorporate different guess and detail coefficients at different levels. This leads at every level to 4 diverse sub-groups HH, HL, LH and LL.

(i) Advantages of Wavelet Transform

The most ordinarily utilized device as a part of sign examination is Fourier Transform (FT), which separates a sign into constituent sinusoids of various frequencies, in this way, changing the sign from time area to recurrence space. Be that as it may, FT has a genuine disadvantage. It loses the time data of the sign. For instance, investigator can't tell when a specific occasion occurred from a Fourier Spectrum. Gabor adjusted the FT to examine just a little segment of the sign at once. The method is called windowing or brief time Fourier Transform (STFT) [5]. It includes a window of specific shape to the sign. STFT can be viewed as a trade off between the time data and recurrence data. It gives some data about both time and recurrence space. Be that as it may, the accuracy of the data is constrained by the extent of the window. Wavelet change (WT) speaks to the following coherent stride: a windowing method with variable size. In this way, it jam both time and recurrence data of the sign. The advancement of sign investigation is appeared in Fig. 1.

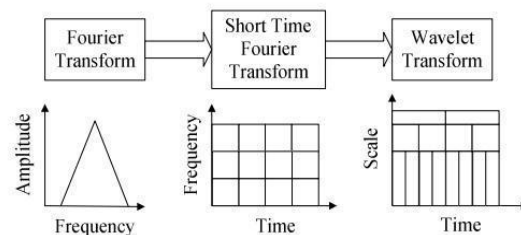

Fig.1.The development of signal analysis

Another advantage of WT is that it adopts “scale” instead of traditional “frequency”, namely, it does not produce a time-frequency view but a time-scale view of the signal. The time-scale view is a different way to view data, but it is a more natural and powerful way [6].

(ii) Discrete Wavelet Transform

The discrete wavelet transform (DWT) is a powerful implementation of the wavelet transform using the dyadic scales and positions. The basic fundamental of DWT is

introduced as follows. Suppose (t) is a square-integrable function, then the continuous wavelet transformed of (t) relative to a given wavelet $\psi(t)$ is defined as:

$$W\psi a, b = \int_{-\infty}^{+\infty} \psi a, t dt \tag{1}$$

Where

$$\psi a, t = \frac{1}{a} \psi \left(\frac{t-b}{a} \right) \tag{2}$$

Here, the wavelet $\psi a, t$ is calculated from the mother wavelet (t) by translation and dilation: a is the dilation factor and b is the translation parameter (both real positive numbers). Several different kinds of wavelets have gained popularity throughout the development of wavelet analysis. The simplest but yet most important wavelet is the Haar wavelet, which is often the preferred one in a lot of applications. Eq. (1) can be discretized by restraining a and b to a discrete lattice ($a = 2^j b & a > 0$) to give the discrete wavelet transform, which can be expressed as follows.

$$cAj, n = D[x n l j (n - 2^j k n)] \tag{3}$$

$$cDj, n = D[x n \square j (n - 2^j k n)]$$

Here $cAj,$ and $cDj,$ refers to the coefficients of the approximation components and the detail components, respectively. $l n$ and (n) Denote for the low-pass filter and high-pass filter, respectively. j and k represent the wavelet scale and translation factors, respectively. DS operator means the down-sampling.

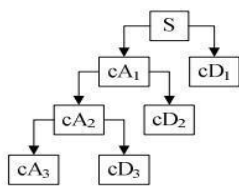

Fig.2 A 3-level wavelet decomposition tree

The above decomposition process can be iterated with successive approximations being decomposed in turn, so that one signal is broken down into various levels of resolution. The whole process is called wavelet decomposition tree.

In case of images, the DWT is applied to each dimension separately. Fig. 3 illustrates the schematic diagram of 2D DWT. As a result, there are 4 sub-band images at each scale. The sub-band $cAj+1$ is used for next 2D DWT. As

the level of decomposition increased, compacter but coarser approximation component was obtained.

B. Noise

Noise in MR images consists of random signals that do not come from the tissues but from other sources in the machine and environment that do not contribute to the tissue differentiation. The noise of an image gives it a grainy appearance. Mainly the noise is evenly spread and more uniform. There are two ways to corrupt an image with noise. A noise image can be simply added to the original image (additive noise), or the noise values can be multiplied by the original intensities (multiplicative noise). From the foregoing the following steps are clear for implementing de-noising algorithms that use the wavelet transform.

- (i) Compute the wavelet transform of the noisy signal.
- (ii) Transform the noisy wavelet coefficients according to specified rule.
- (iii) Find the inverse of the transformed coefficients.

Image independent noise is often described by an additive noise model, where the noise image $f(i, j)$ is the sum of the true image $s(i, j)$ and the noise $n(i, j)$:

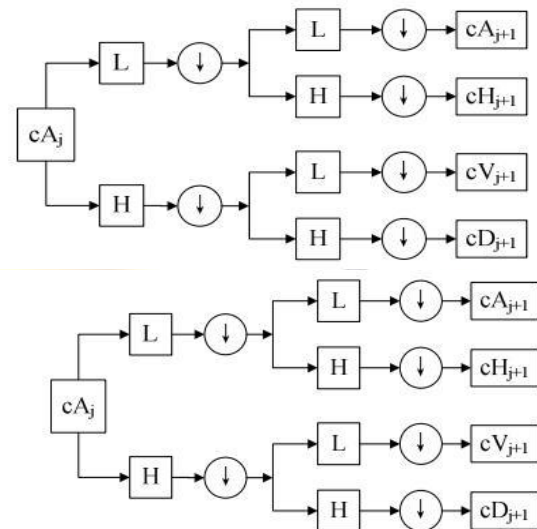

Fig.3 Figure displaying the two level Forward and Inverse Discrete Wavelet transform

$$f(i, j) = s(i, j) + n(i, j) \tag{4}$$

In many cases, additive noise is evenly distributed over the frequency domain (i.e. white noise), whereas an image contains mostly low frequency information. Hence, the noise is dominant for high frequencies and its effects can be reduced using some kind of low-pass filter. The classification of noise is based upon the shape of the probability density function or histogram for the discrete

case of the noise. The first type of noise to be presented is uniform noise. Fig.4 shows a histogram of a uniform noise distribution.

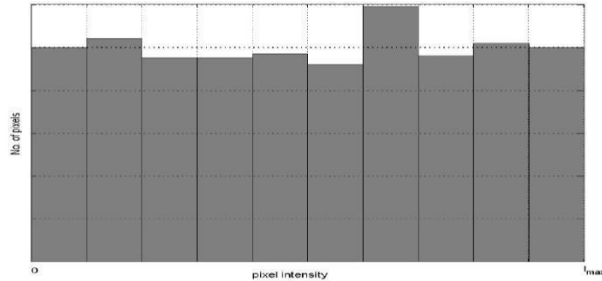

Fig.4 Uniform distribution histogram for 1000 values generated using the rand MATLAB function

The most common type of noise and the one that is mostly encountered is the Gaussian noise. Gaussian distribution is assumed to be symmetrical about a mean of zero. The standard deviation (σ) is a measure of the amount of spread around the central peak. At low standard deviations, the central bins are concentrated near the mean and the peak is very tall and sharp. At high deviations the peak is lower and values are more evenly distributed to outlying bins. The probability of larger and larger deviations can be seen to decrease rapidly. Its probability density

C. Thresholding

Thresholding is a technique used for signal and image de-noising. Wavelet hard thresholding de-noising and soft thresholding de-noising (wavelet shrinkage de-noising) [3] provide a new way to reduce noise in signal. Let $W(\cdot)$ and $W^{-1}(\cdot)$ forward and inverse wavelet transform operators. Let $D(\cdot, \lambda)$ denote the thresholding operator with threshold λ .

The practice of threshold Denoising consists of the following three steps:

$$Y=W(x) \tag{7}$$

$$Z=D(Y,\lambda) \tag{8}$$

$$\hat{x} = W^{-1}(Z) \tag{9}$$

Hard thresholding and soft thresholding are only different In step 3. In the case of hard thresholding,

$$D(Y, \lambda) \equiv Y \text{ if } \|Y\| > \lambda \text{ 0 otherwise} \tag{10}$$

In the case of soft thresholding, or Wavelet shrinkage,

$$D(Y, \lambda) \equiv \text{sign}Y \|Y\| - \lambda \text{ if } \|Y\| > \lambda \text{ 0 otherwise} \tag{11}$$

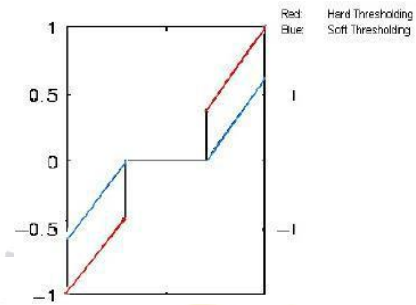

Figure.5 graphically shows the difference between the practice of soft and hard thresholding

I. EXPERIMENTAL RESULT

For our test experiments we have considered an additive noise with a uniform distribution which has been used to corrupt our simulated and real MR test image data. Artificially adding noise to an image allows us to test and assess the performance of various wavelet functions. To reduce computational time a region of interest is cropped (extracted) for de-noising (Fig.8).



Fig.6 (a) Original MR image slice and (b) the chosen sub image for the de-noising application

Results from real 2D MRI data

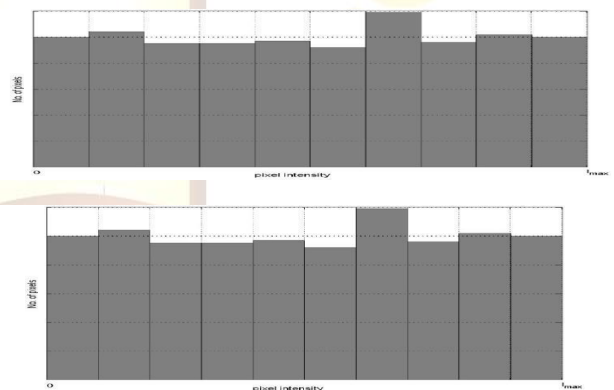

Fig.7 Figure displaying the distribution histogram for values generated using the rand MATLAB function

We have done simulations with uniform random noise added to the MR image. An example of a noisy magnetic resonance image (MRI) which consists of 128×128 pixels is shown in Fig.6. As can be seen in the background the image has been uniformly corrupted with additive noise. The de-noising techniques discussed in the previous section are applied to the noisy MR image to test the efficiency of the different threshold methods.

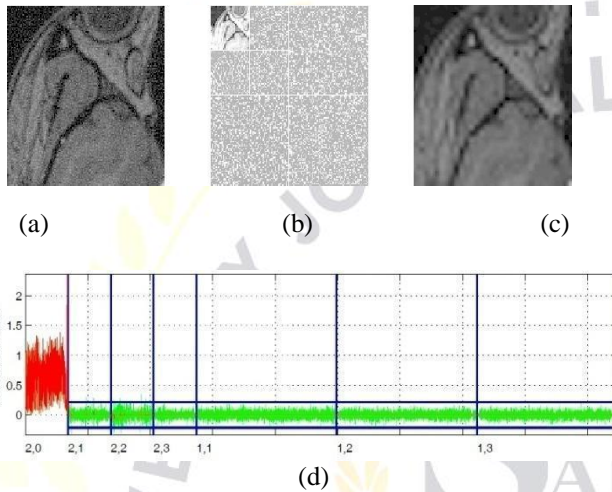

Fig 8. The 2-D image decomposition of the (a) noisy MR image using a *db4* wavelet function, (b) the approximation image (low-frequency component) is in the top-left corner of the transform display, the other sub images contain the high frequency details, (d) global thresholding of the sub band coefficients, and (c) shows the resulting de-noised MR image.

Comparison of de-noising results for a various set of wavelets for the 128×128 MR image, corrupted with additive uniform random noise are shown in Tabs.1, 2 and 3. The MSE and PSNR values from the experimental results show that *db4* wavelet yields significantly improved visual quality as well as lower mean square error (MSE) and higher PSNR value compared to other wavelet functions.

The simplest Haar wavelet produces the worst results as evidenced by the higher MSE, lower PSNR values and poor visual quality. Table.1 shows the result of performing the de-noising algorithm with different types of wavelets, both for one and two levels of decomposition using the global thresholding method. This was obtained by the *db4* wavelet. It can also be seen that the background noise has been eliminated and the edge details are preserved.

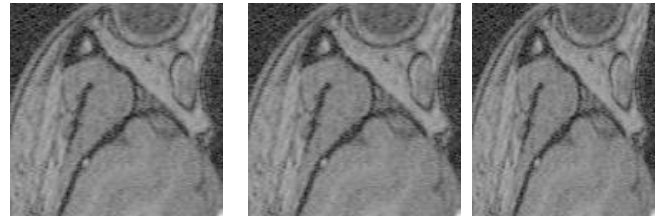

Fig.10 Figure Displaying the Extracted Images

II. CONCLUSION

The de-noising process comprises of breaking down the picture, thresholding the subtle element coefficients, and reproducing the picture. The deterioration methodology of the de-noising illustration is expert by utilizing the DWT. Wavelet thresholding is a compelling method for de-noising as appeared by the exploratory results acquired with the utilization of various sorts of wavelets. Thresholding techniques executed involved the all inclusive worldwide thresholding, level (sub band) thresholding and ideal thresholding. More levels of deterioration can be played out, the more the levels disintegrated a picture or volume, the more detail coefficients we get. Yet, for de-noising the uproarious MR information sets, two-level deterioration gave adequate commotion lessening. In this Paper we have introduced the speculation of the DWT strategy for the 2-D case. The subsequent calculations have been utilized for the handling of boisterous MR picture. Trial comes about have demonstrated that in spite of the effortlessness of the proposed de-noised calculation it yields fundamentally better results both as far as visual quality and mean square mistake values.

Considering the straightforwardness of the proposed strategy, we trust these outcomes are exceptionally reassuring for different types of de-noising. The fourth request Daubechies wavelet (*db4*) gave the best results contrasted with different wavelets and the basic Haar wavelet creates the most noticeably bad results. Nonetheless, the Haar wavelet is a helpful and straightforward wavelet which is ordinarily utilized for showing reasons for the discrete wavelet change. DWT utilizing a *db4* produces more keen edges and holds more detail, giving a nearer similarity to the first than alternate wavelets. The commotion presumption utilized as a part of Donoho's inference comes up short when pictures are not defiled with added substance clamor (uniform irregular commotion, Gaussian clamor). Nonlinear picture preparing strategies are required to expel multiplicative clamor while

direct spatial sifting techniques (DWT) are utilized to evacuate added substance commotion. In the event that for instance we don't have a reference picture it is conceivable to take the normal of different pictures of the same picture at the same commotion level and this structure is likewise valuable for evacuating clamor. At last, an incredible favorable position of the wavelet change is that regularly countless point of interest coefficients ends up being little in extent, truncating (expelling) these little coefficients from The VWCA strategy fundamentally concentrates on enhancing the CH length, participation term and security and second to maintain bunch solidness as could reasonably be expected. Utilizing VWCA, correspondence cost for joining to another group in system diminishes in light of the fact that the participation span for each vehicle has moved forward. What's more, utilizing the entropy word as a part of the weighted total method, VWCA can diminish the quantity of overheads made by rapid vehicles. VWCA have the capacity to upgrade system network while selecting group heads.

VWCA make utilization of distrust quality in the weighted whole operation. The distrust esteem has been gotten from this work next proposed checking pernicious vehicle (MMV) calculation. Utilizing distrust esteem, vehicles that have lower question esteem than their neighbors are chosen as bunch heads. Along these lines, group heads are more solid vehicles than different vehicles in the system utilizing their PDR esteem. In future works creating calculations for a city situation in light of the procedures proposed here for expressways and presenting another security calculation in view of key circulation and the proposed grouping calculation algorithm.

REFERENCES

- [1] Emil Dumić, Sonja Grgić, Mislav Grgić, "New image-quality measure based on wavelets," *Journal of Electronic Imaging* 19(1), 011018 (Jan-Mar 2015)
- [2] Dipali M. Joshi, Dr. N. K. Rana, V. M. Misra, "Classification of Brain Cancer Using Artificial Neural Network," *IEEE* 2014
- [3] Junhui Qian, "Denoising by Wavelet Transform"
- [4] S. Chaplot, L.M. Patnaik, and N.R. Jagannathan, "Classification of magnetic resonance brain images using wavelets as input to support vector machine and neural network," *Biomedical Signal Process. Control*, vol.1, pp. 86-92, 2006
- [5] L. Durak, "Shift-invariance of short-time Fourier transform in fractional Fourier domains," *Journal of the Franklin Institute*, vol. 346, pp. 136-146, 2009
- [6] J. Schmeelk, "Wavelet transforms on two-dimensional images," *Mathematical and Computer Modeling*, vol. 36, pp. 939-948, 2002. [7] Yudong Zhang, Zhengchao Dong, Lenan Wu, Shuihua Wang, Zhenyu Zhou, "Feature extraction of brain MRI by stationary wavelet transform," *IEEE* 2010.
- [7] Salim Lahmiri and Mounir Boukadoum, "Classification of Brain MRI using the LH and HL Wavelet Transform Sub-bands," *IEEE* 2010
- [8] Olawuyi, N.J, Iroju, O.G, Idowu, C.S. & Olaleke, J.O, "Comparative Analysis Of Wavelet-Based Denoising Algorithms on Cardiac Magnetic Resonance Images (MRIs)," *African Journal Comp & ICT* Vol 4. No.1. June, 2011.
- [9] F.Yousefi Rizi, H.Ahmadi Noubari and S.K Setarehdan, "Wavelet Based Ultrasound image Denoising: performance analysis and comparison," 33rd annual international conference of the IEEE EMBS Boston, Massachusetts USA August 30-September 3, 2011
- [10] R.C. Gonzalez and R. E. Woods, "Digital Image Processing (2nd Edition)," Addison-Wesley, 2002.
- [11] R. C. Gonzalez, R. E. Woods, and S. L. Eddins, "Digital Image Processing Using MATLAB," Prentice Hall, Englewood Cliffs, NJ, USA, 2004.
- [12] I. Daubechies, "Orthonormal Bases of Compactly Supported Wavelets," *Communications on Pure Applied Mathematics*, 41:909-996, 1988.
- [13] I. Daubechies, "The Wavelet Transform, time-frequency localization and signal analysis," *IEEE Trans. Info. Theory*, 36:961-1005, 1990.
- [14] I. Daubechies, "Ten Lectures on Wavelets," Society for Industrial and Applied Mathematics, Philadelphia, Pennsylvania, 1992. 357p.
- [15] D.L. Donoho, "De-noising by Soft Thresholding," *IEEE Trans. on Information Theory*, 38(2):613-627, 1995.
- [16] D.L. Donoho and I.M. Johnstone, "Ideal Spatial Adaption via Wavelet Shrinkage," *Biometrika*, 81(3):425-455, 1994.
- [17] The Math-Works. *Matlab Image Processing Toolbox*, , Natick, Massachusetts 01760, May 1997.
- [18] The Math-Works, *Image Processing Toolbox User's Guide*, Natick, Massachusetts 01760, 1998.
- [19] A. B. Watson, R. Borthwick, and M. Taylor, "Image quality and entropy masking In Human Vision," *Visual Processing, and Digital Display VIII*, volume 30(16) of SPIE Proceedings, San Jose, CA, USA, 1997.
- [20] A. B. Watson and J. A. Solomon, "A model of visual contrast gain control and pattern masking," *Journal of the Optical Society*